

CS-PIC-2 is a high quality pneumatic machine that employs a superior electronic safety system that doesn't interfere with the operator's work. This advanced feature increases the operational capabilities of the pneumatic machine. The foot pedal leaves the operator's hands free to place grommets and washers more efficiently.

- ▶ **Hand-free use.** The CS-PIC-2 is operated by a pneumatic foot pedal. Thus, the operator can use both hands for loading the grommet and adjusting the material during application.
- ▶ **Advanced safety system.** Unlike most pneumatic machines' mechanical safety systems that limit the capabilities of the machine, the CS-PIC-2's safety system senses human static electricity. If the user touches any metal part of the machine it will immediately stop the machine. This system widely increases the variety of projects you can handle with the CS-PIC-2 without risk to the operator.
- ▶ **European made.** The high quality components made in Europe give this machine a much longer life than more cheaply made exports.
- ▶ **Self lubricating.** No need for external greasing. The CS-PIC-2 greases itself with its built-in components.
- ▶ **Moisture control.** Collects the humidity compressed air before reaching the machine. This helps prevent rusting and increases both the life and performance of the cylinder.
- ▶ **Air compressor compatibility.** The CS-PIC-2 will work with house air or a small air compressor. It usually runs on approximately 80 PSI, but the air pressure level is adjustable to fit your specific job.
- ▶ **Completely assembled.** Comes as shown in the picture pre-mounted to the table.
- ▶ **"Portable cart" and "double force" versions also available.**
- ▶ **Optional laser pointer.** A laser pointer can be installed to show the position where the grommet will be attached.
- ▶ **Interchangeable dies.** All ClipsShop self-piercing dies up to size #5.5 and #12 are compatible with the CS-PIC-2.
- ▶ **Suitable for applications on various materials.**

With all these superior features, the **CS-PIC-2** is the perfect choice for individuals looking for a reliable pneumatic machine to apply large quantities and variable sizes of grommets with a single machine.



PNEUMATIC PRESS CS-PIC-2

PNEUMATIC PRESS: CS-PIC-2

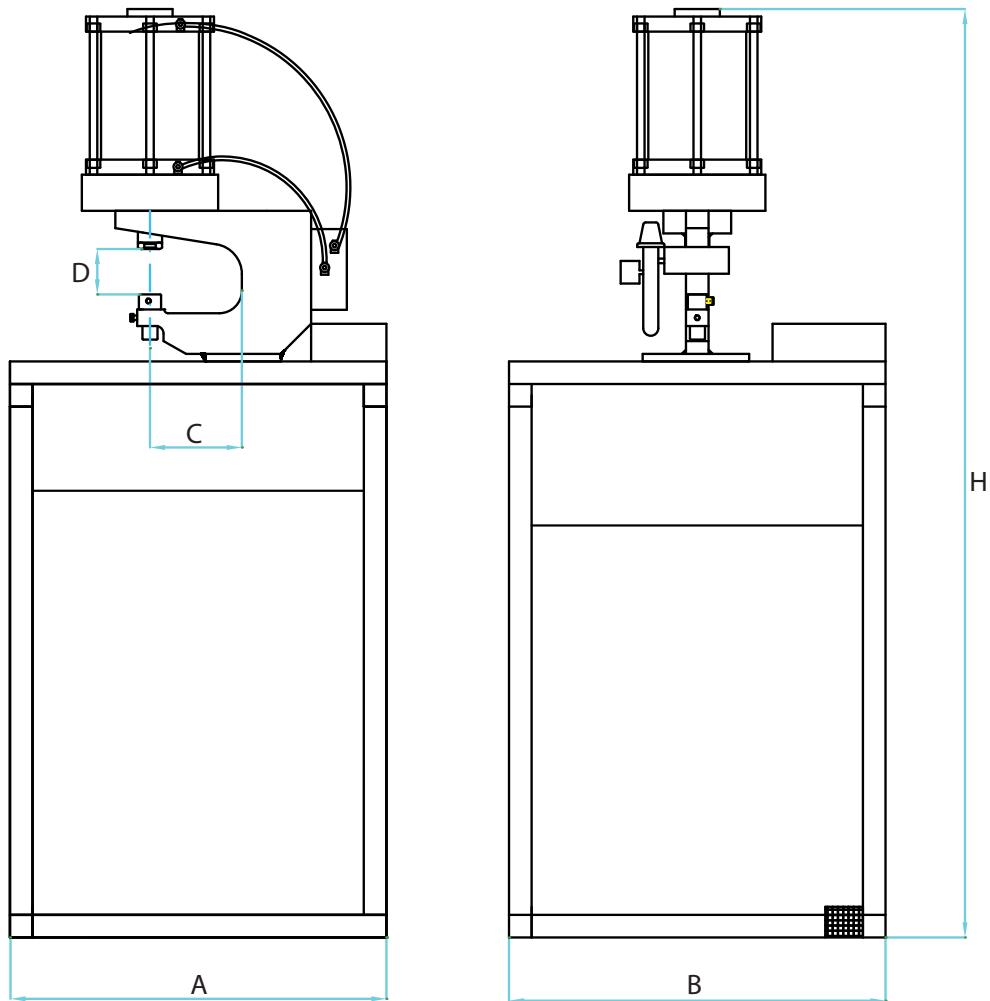

Dimensions	Inch / mm
A	18.9 / 480
B	18.9 / 480
C	4.72 / 120
D	2.95 / 75
H	47.64 / 1210

Technical Features

Compatible grommet sizes	All standard sizes to #12
Weight	115 lbs / 52.2 kg 83 lbs / 37.5 kg ("Portable cart" version)
Overall dimensions	50.75" h x 21.25" w x 21.25" d 15.75" l x 19.75" w ("Portable cart" version)

#12 grommets require more force than smaller self-piercing grommets.
The double-force version may yield better results.

METAL.com
grommets