



## HAND PRESS CSTEP-1

The ClipShop CSTEP-1 is a perfect, portable, budget-minded grommet hand press for occasional to moderate use. Thousands of worldwide CSTEP-1 owners have been enjoying their user-friendly CSTEP-1s for years. The practice of using a hammer for manual grommet application is a thing of the past! CSTEP-1 is a must-have for anyone who applies grommets on occasion using hand tools and a hammer. Its high quality and affordable price make it the perfect entry-level hand press.

- **Affordable machine.** So affordable, why would you want to use a hammer?
- **Simple to use.** Even amateur users can operate this machine easily with little training.
- **Small and practical machine.** Approximately 10 lbs and 12 inches high. Easy to handle and easy to move. Takes up little room on a bench or table.
- **Interchangeable self-piercing dies.** By piercing the hole during application, our machines eliminate a production step. All METALgrommets.com self-piercing dies up to size #3 are compatible with the CSTEP-1 machine.
- **Suitable for applications on various materials.** Vinyl, corrugated plastic, other plastics, fabric, poster board and many other substrates.
- **Heavy duty durable machine.** Lasts for years with little maintenance.
- **1 year ClipsShop warranty against manufacturing defects.**

**Please note:** Unlike most traditional grommet machines that allow only one size of grommet application, the CSTEP-1, like all other METALgrommets.com machines, can set various sizes of grommets by a simple die changing process which takes only minutes.

# HAND PRESS CSTEP-1

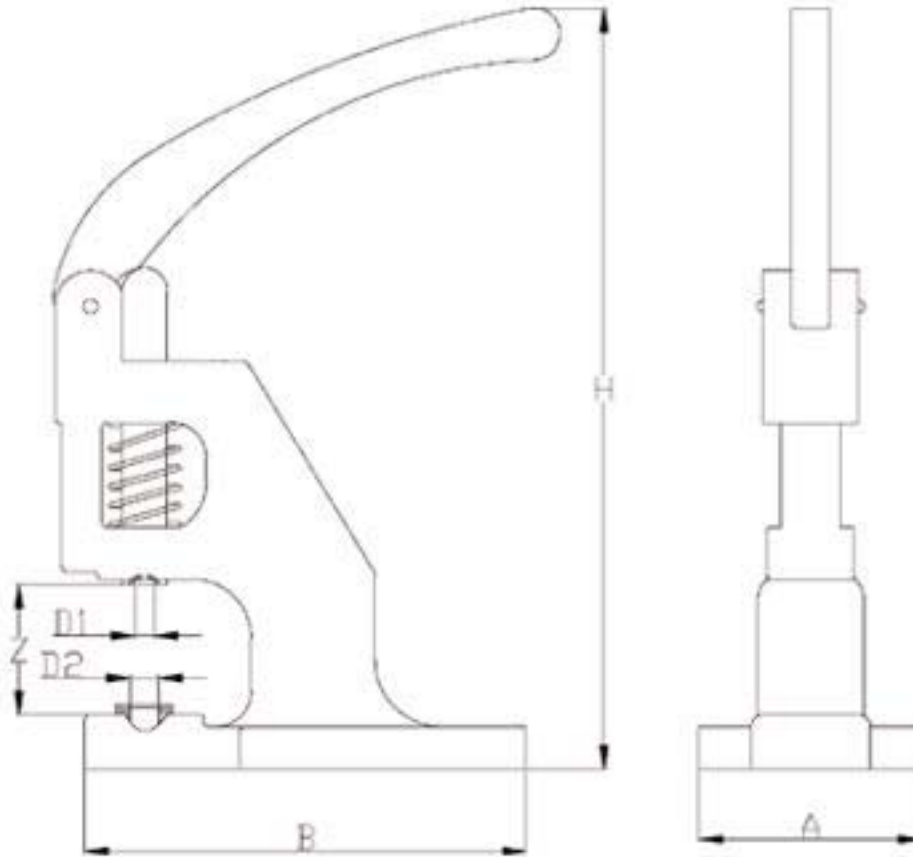

## Dimensions

## Inch/mm

A	3.74 / 95
B	7.28 / 185
H	12.40 / 315
Z	1.97 / 50
D1	0.25 / 6.35
D2	0.47 / 12

## Technical Features

<b>Compatible grommet sizes</b>	All standard sizes to #3
<b>Weight</b>	9.9 lbs / 4.5 kg
<b>Overall dimensions</b>	12.4" h x 3.7" w x 9.4" d