

Applying grommets with a hand press has never been so easy. The innovative design of the **CSTEP-2** offers many advantages compared to standard hand press machines. Keep reading and we are sure you will agree that no other hand press can match the benefits and value of the **CSTEP-2**!

- **Unique lever design.** Our newly engineered lever helps reduce the hand force required to apply grommets as compared to a typical hand press.
- **Enlarged throat depth.** The deeper throat allows much more flexibility in the placement of your grommets. Apply grommets as much as 4" in from the edge of your project – more than **DOUBLE** a typical hand press!
- **Soft handle grip.** Our new soft handle grip provides increased comfort for the user during application.
- **Easy to move.** Sometimes a large project requires the press to be moved around the work during application.
- **Simple to use.** Even amateur users can operate this machine easily with little training. No special maintenance is needed.
- **Interchangeable self-piercing dies.** All METALgrommets.com self-piercing dies up to size **#5.5 (11/16")** are compatible with the CSTEP-2 machine. By piercing the hole during application, our machines eliminate a production step.
- **Heavy duty durable machine.** This machine will provide years of professional performance. All presses include a 1 year manufacturer's warranty against defects.

Please note: Unlike most traditional grommet machines that allow only one size of grommet application, the CSTEP-2, like all other METALgrommets.com machines, can set various sizes of grommets by a simple die changing process which takes only minutes.

Master Distributor for
CLIPS SHOP
In the Americas.

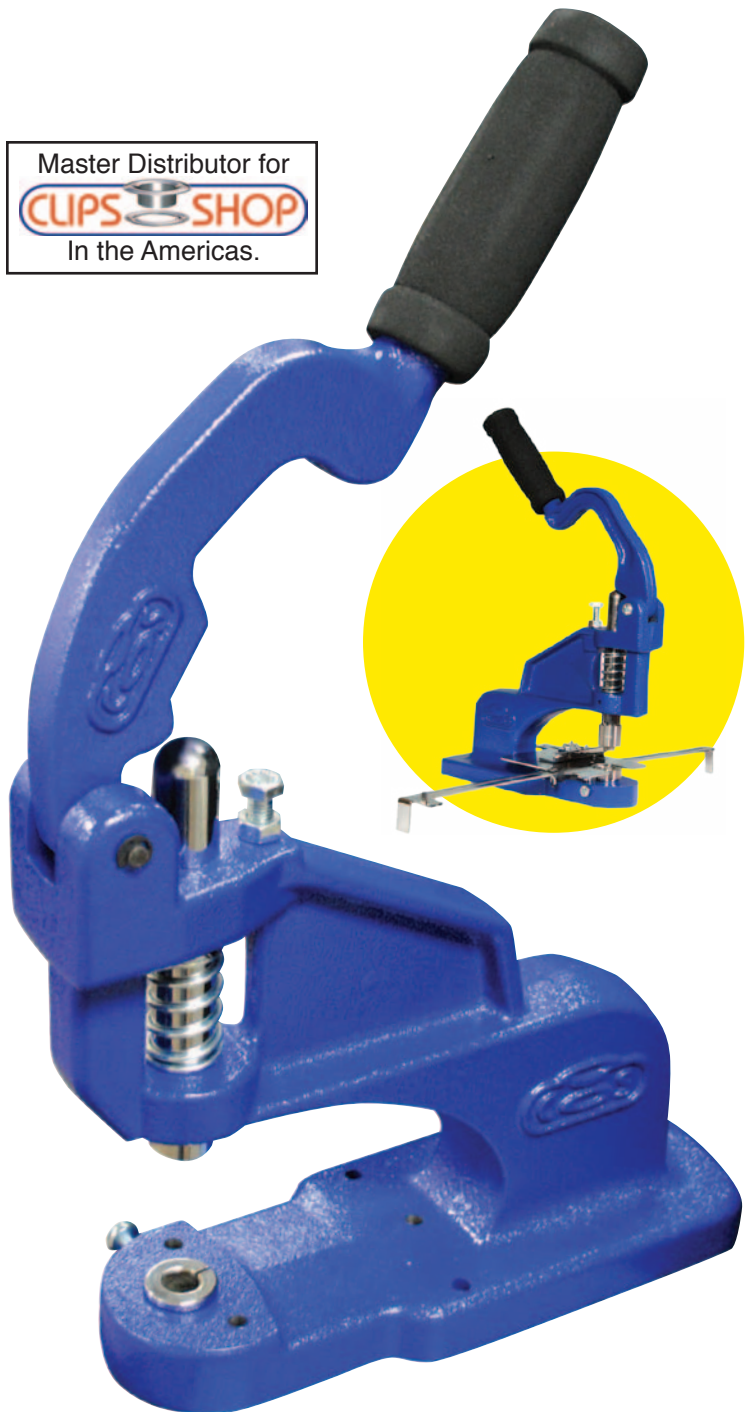

HAND PRESS CSTEP-2

**USER-FRIENDLY
DESIGN**

999-2044

HAND PRESS CSTEP-2

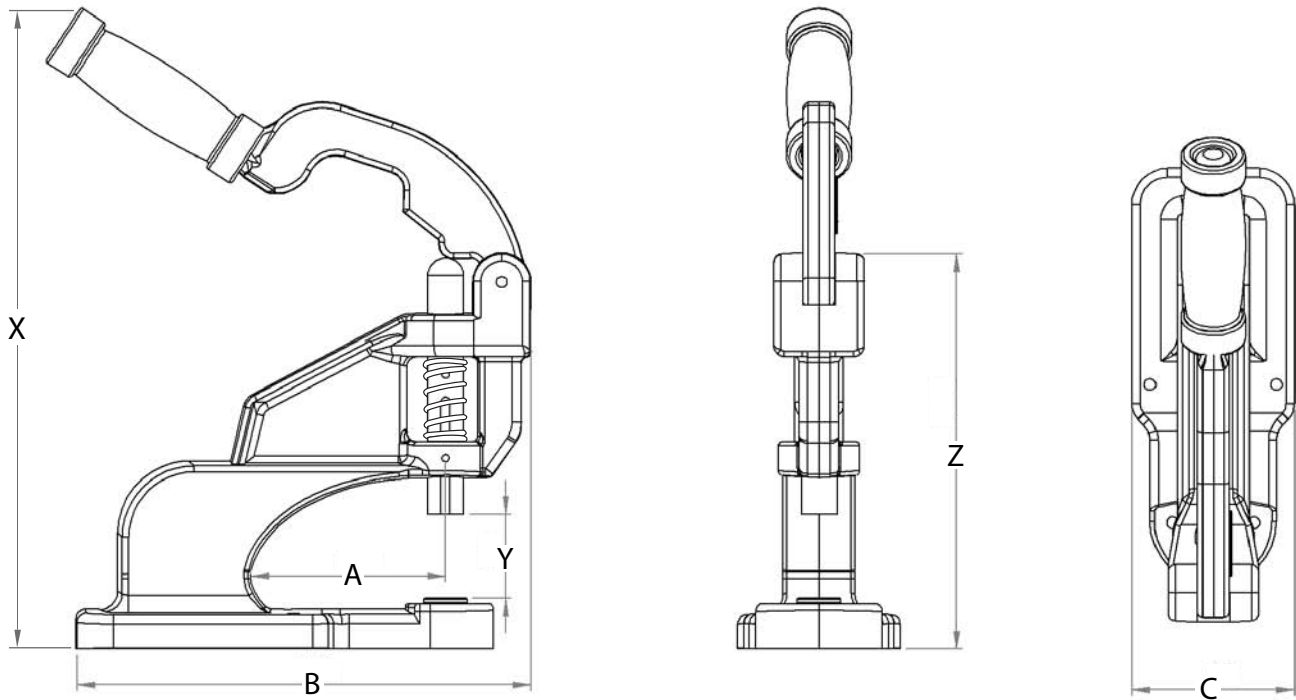

DIMENSIONS	INCHES / MM
A	3.937 / 100
B	9.843 / 250
C	3.543 / 90
X	14.567 / 370
Y	1.969 / 50
Z	8.661 / 220

TECHNICAL FEATURES

Compatible grommet sizes	#5.5, #3, #2, #1, #0, #00, #X00, #XX00
Weight	16.25 lbs / 7.38 kg
Overall dimensions	14.567" x 3.543" x 9.843"

Compatible with the ClipsShop GrommetSniper™